

Graflex Boresight Camera Accessory (BCA)*

The *Graflex Incorporated* Video Boresight Camera Accessory, or BCA, works with any existing Graflex boresight and maintains the World Class accuracy of the proven Graflex Boresight Telescope Assembly. Boresighting can now be performed by one person.

Result: Best Accuracy at the Lowest Cost!!!



Graflex BORESIGHT + Graflex BCA = Graflex VIDEO BORESIGHT

The BCA weighs less than 90g, and is packaged in a self-contained, sealed shipping/storage container with a monitor and built-in rechargeable power supply. The BCA will operate for over 8 hours without external power, or charging. The BCA can be operated or charged by 10 to 36VDC vehicle power, or the included 100VAC-240VAC, 50/60Hz charger. The BCA is offered in either monochrome (B&W), or color, with either NTSC or PAL video format. Other companies may claim to have an accurate video boresight, but none can match the accuracy of the proven Graflex optical Boresight Telescope, with over 65,000 units produced to date, in 8X, 10X and 12X magnifications. The BCA works with all of these fielded Graflex Boresights, with minimal training required.

GRAFLEX INC. BORESIGHT CAMERA ACCESSORY FEATURES:

- Very lightweight (<90 grams), yet rugged
- Small Size – 51mm diameter X 75mm length
- Fits all Graflex produced Boresight Telescopes, whether 8X, 10X, or 12X Magnification
- Dual Use – Fits any standard 1.25" astronomical telescope eyepiece
- Parallax Free – Accuracy is not affected by camera placement on the eyepiece
- Anodized Aluminum construction and environmentally sealed camera compartment
- Anti-reflection coated glass optical window protects the camera / lens
- Day or Night Boresighting with the illuminated reticle in the Graflex Boresights

GENERAL SPECIFICATIONS

- ❖ Operate / Charge Voltage: 10 to 36 VDC, at 800mah
- ❖ Rechargeable NIMH 12VDC, 2000mah battery
- ❖ Included 100VAC - 240VAC, 50/60Hz Charger
- ❖ Color or Monochrome Camera, NTSC or PAL Format
- ❖ Video Format: NTSC or PAL
- ❖ Monitor: Color / Monochrome, NTSC / PAL Auto-Switching
- ❖ Cushioned pouch for camera storage in the case.
- ❖ Rugged, sealed Shipping / Storage Case holds everything with a total weight of about 2.5Kg.



GRAFLEX Incorporated



Always on Target

15855 Assembly Loop – Suite 100 - Jupiter, FL 33478 – USA

Phone: (561)691-5959 Fax: (561)691-5983 E-mail: Sales@Graflex.com

Graflex Video Boresight Camera Accessory (BCA)

MECHANICAL DRAWING

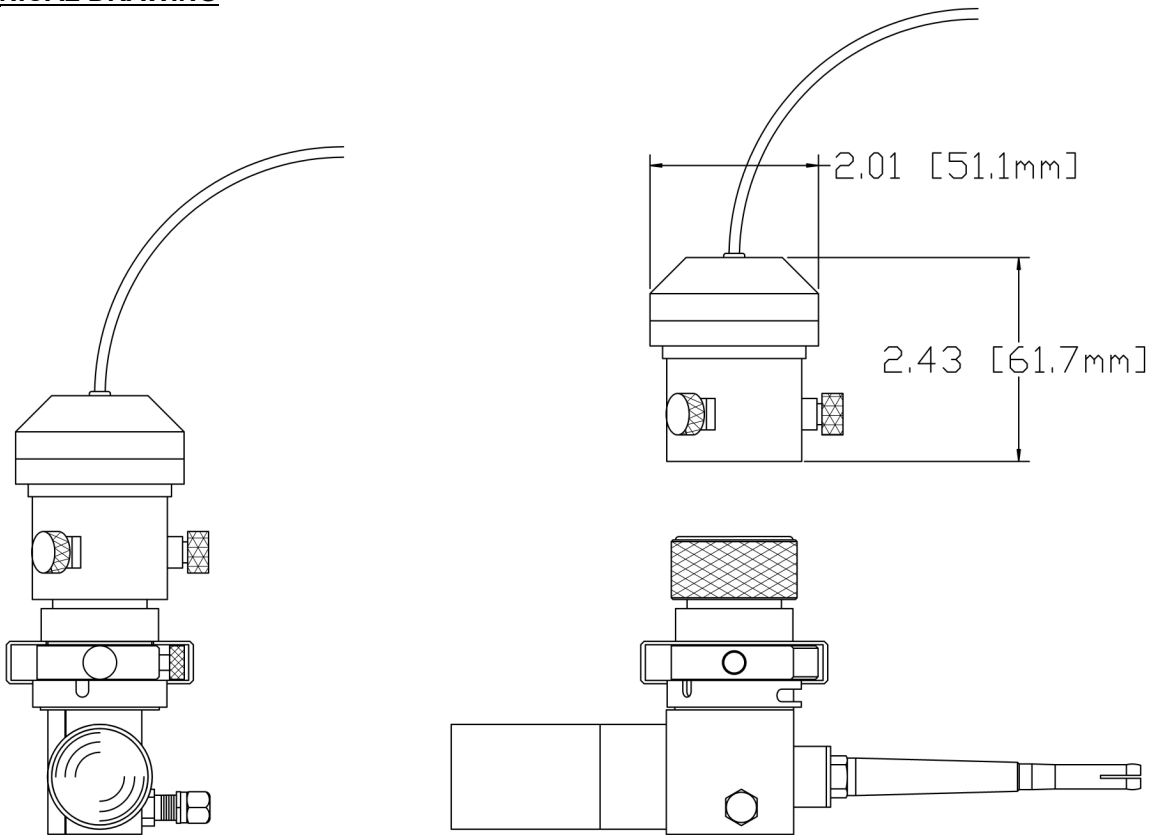

FRONT VIEW (BCA on Boresight)

SIDE VIEW (BCA Positioned Above Boresight)

ENVIRONMENTAL SPECIFICATIONS

Temperature Storage -35 thru +71° C*
 Operation -20 thru +50° C*
 (* Contact Factory)

Vibration Contact Factory

Shock Contact Factory

Humidity, Rain, Sand, Salt Fog, Fungus, Solar Radiation

ORDERING GUIDE

Please feel free to contact us by phone, or e-mail, to assist with specification of the Boresight Camera Accessory for your application. Some of the specifications and options that need to be considered are:

- Vehicle Type & Weapon Caliber
- Color or Monochrome Camera
- Video Format: NTSC, or PAL
- With (or without) Monitor
- With (or without) Rechargeable Battery System
- Cable Lengths for Power, and Camera cables
- Vehicle Connectors for Power Cable



SHIPPING / STORAGE CONTAINER

*Patent Pending

GRAFLEX Incorporated
WWW.GRAFLEX.COM